

PARÇA KODU PART CODE	PARÇA ADI PART NAME	s ÖLÇÜSÜ (KALINLIK) s MEASURE (THICKNESS)	Malzeme Material	Kaplama / Coating		
				SN	AG	Nİ
TŞ 2409 DP	1 NO 2.TERMİNAL Ø3.5 =DP=	0.45±0.05	(CuZn30) Pirinç / Brass	-	-	-
TŞ 2409 RP	1 NO 2.TERMİNAL Ø3.5 =RP=	0.45±0.05	(CuZn30) Pirinç / Brass	-	-	-
TŞ 2409 RPK	1 NO 2.TERMİNAL Ø3.5 =RPK=	0.45±0.05	(CuZn30) Pirinç / Brass	+	-	-
TŞ 2409 RÇN	1 NO 2.TERMİNAL Ø3.5 =RÇN=	0.50±0.05	Paslanmaz Sac(430)	-	-	-

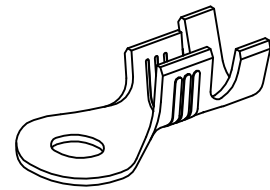
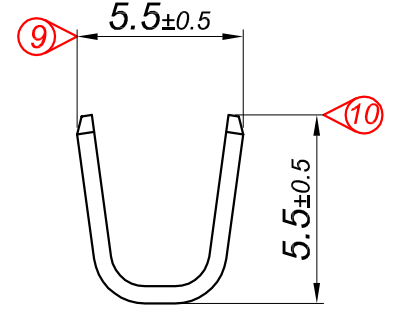
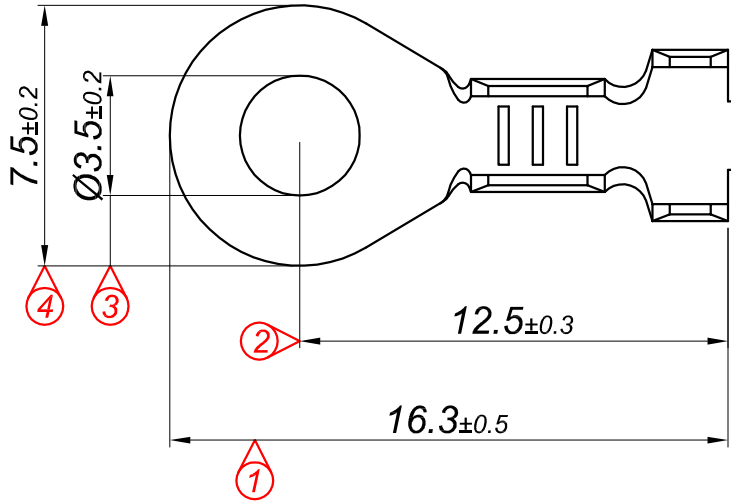
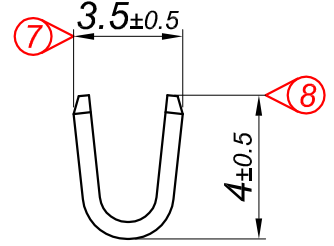
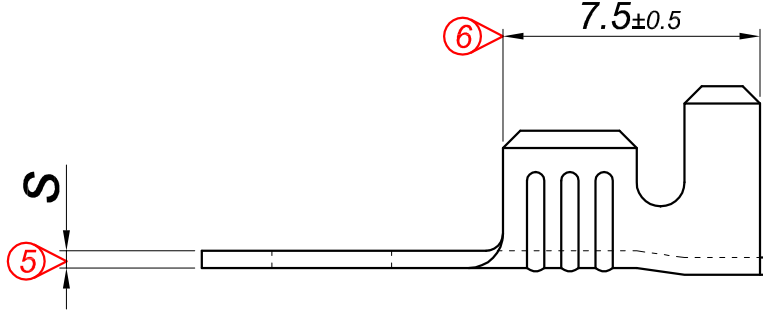

Perspektif
Perspective

Kalıp çıkış yönü
Mold output direction

Makara açılım yönü
Reel opening direction

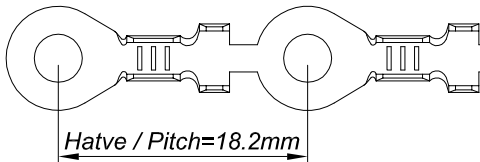

Ölçek
Scale : 3 / 1

Kablo Kesiti
Wire Section : 1 - 2.50 mm²

Resim üzerinden ölçü almayınız
do not measure on drawing

Tarih / Date	19.07.2013	İmza /Signature	Ölçek /Scale		
Çizen / Desing	M.Yağcı		5 / 1	01	ÇİFTLİ KALIP YAPILMIŞTIR.
Onay / Approval	S.Gölcük			No	Değişiklik / Revision
					Tarih/Date



Parça Adı:
Part Name

1 NO 2.TERMİNAL Ø3.5

Parça Kodu:
Part Code

TŞ 2409